

## 产品技术规格书 (Product Technical Specification)

No.	名称 (Name)	规格 (Specification)	No.	名称 (Name)	规格 (Specification)			
1	型号 (Model)	AZURE-0814SWIR-S	14	视场角 F.O.V (DxVxH)	2/3	1/2	1/3	
2	物料代码 (Material Code)	3. A01. 010081401-S			D	61	53.1	41.1
3	靶面格式 (Image Format)	2/3"			H	54.8	43.6	33.4
4	分辨率 (Resolution)	60lp/mm			V	42.8	33.4	25.4
5	焦距 (Focal Length)	8.5mm	15	接口 (Mount)	C			
6	后截距 (Back Focus)	9.91mm	16	适用物距 (Suitable Distance)	0.2-∞m			
7	F值 (F/No.)	1.4	17	最佳物距 (Optimum Working Distance)	0.7m			
8	光圈 (Iris Type)	Manual	18	镀膜 (Coating)	800nm-1700nm			
9	畸变 (Distortion)	<-1.2%	19	外形尺寸 (Dimension)	φ38.5×50.4mm			
10	通光口径 (Lens Effective Diameter)	前面 (Front)	φ24.9mm	20	重量 (Weight)	g		
		后面 (Back)	φ8.54mm	21	工作温度 (Operating Temperature)	-20°C~+65°C		
11	相对照度 (Relative Illuminate)	70.6%	22	镜头组成 (Lens Construction)	11-8			
12	光学总长 (TTL)	65mm	23	最大主光线入射角 (CRA)	16.38°			
13	设计波长 (Design Wavelength)	900~1700nm	24	滤镜尺寸 (Filter Thread)	M35.5×0.5			

Size:

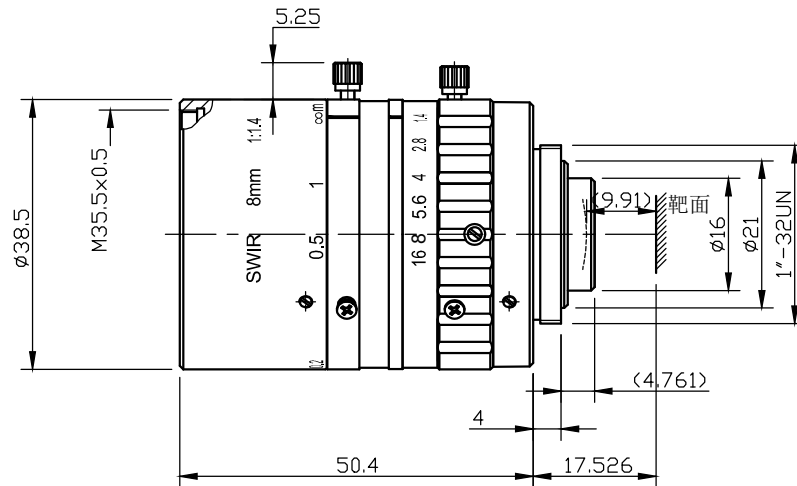

Unit:mm

Draw	Check	Recheck	Approval	福建浩蓝光电有限公司 AZURE Photonics Co.,Ltd